

# Model year 2007 SUN ODYSSEY DS

## Sun Odyssey 39 DS



## Sun Odyssey 42 DS



## Sun Odyssey 49 DS

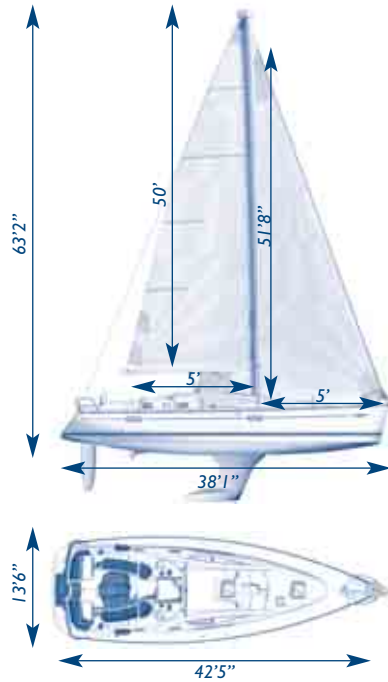
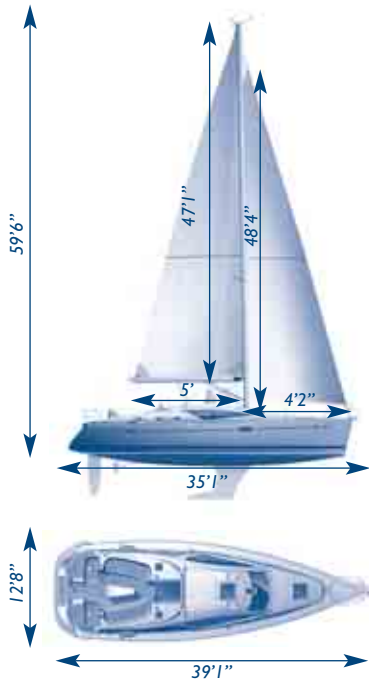

Certification conform with CE regulation.

	SO 39 DS	SO 42 DS	SO 49 DS
<b>Overall length</b>	39'1"	42'5"	49'1"
<b>Hull length</b>	38'1"	41'3"	48'4"
<b>Waterline length</b>	35'1"	38'	42'4"
<b>Beam</b>	12'8"	13'6"	14'8"
<b>Displacement</b> <i>light load with deep draft keel</i>	15,984 lbs	18,080 lbs	27,778 lbs
<b>Standard draft</b> <i>cast iron fin keel with elongated bulb and exterior epoxy barrier coat</i>	6'6"	7'1"	7'1"
<b>Standard keel weight</b>	5,026 lbs	5,628 lbs	8,267 lbs
<b>Shoal draft</b> <i>cast iron fin keel with elongated bulb and exterior epoxy barrier coat</i>	5'	5'3"	5'5"
<b>Shoal keel weight</b>	5,401 lbs	6,31 lbs	9,040 lbs
<b>CE category</b> (* in process)	A8 *	A8/B10/C12	A10/B12/C14
<b>Architecte / Designer</b>	M. Lombard / V. Garroni	M. Lombard / V. Garroni	P. Briand / V. Garroni
<b>Water</b> <i>rotomolded tanks located under forward and aft berths with separate deck fills</i>	94 Usgal	94 Usgal	185 Usgal
<b>Fuel</b> <i>rotomolded tank located under aft berth with deck fill</i>	34 Usgal	34 Usgal	63 Usgal
<b>Holding tank</b> <i>rotomolded tank located in aft, port head compartment with valve for overboard discharge via gravity and deck fitting for pump out</i>	22 Usgal	34 Usgal	24/36 Usgal
<b>Fridge</b> <i>compartment with vertical access</i>	50 Usgal	50 Usgal	60 Usgal

	SO 39 DS	SO 42 DS	SO 49 DS
<b>Furling mainsail</b> <i>high-tenacity Dacron cloth, Sunbrella® UV luff protection, Rutgerson® stainless steel eyes</i>	357 sqft	377 sqft	419 sqft
<b>Classic mainsail (optional)</b> <i>80% battened, high-tenacity Dacron cloth, Rutgerson® stainless steel eyes and 3 reinforced reef points, 2 auto reefs, includes Lazy Bag in Sunbrella® Captain Navy fabric and integrated lazy jacks</i>	391sqft	421 sqft	-
<b>Classic mainsail (optional)</b> <i>100% battened, high-tenacity Dacron cloth, Rutgerson® stainless steel eyes and 3 reinforced reef points, 2 auto reefs and 1 classic reef, includes Lazy Bag in Sunbrella® Captain Navy fabric and integrated lazy jacks</i>	-	-	530 sqft
<b>Furling genoa 122%</b> <i>high-tenacity Dacron cloth, Sunbrella® UV luff protection, Rutgerson® stainless steel eyes</i>	368 sqft	456 sqft	-
<b>Furling genoa 140%</b> <i>high-tenacity Dacron cloth, Sunbrella® UV luff protection, Rutgerson® stainless steel eyes</i>	-	-	680 sqft
<b>Spinnaker</b> <i>optimal size for boat (not available from Jeanneau)</i>	1044 sqft	1313 sqft	1427 sqft
<b>Total sail area</b> <i>for standard mast and sails</i>	725 sqft	833 sqft	1099 sqft

■ Standard □ Option - Not available

		SO 39 DS	SO 42 DS	SO 49 DS
Winches	<b>Genoa winches</b> 2 x Harken 44.2 self-tailing winches	■	-	-
	<b>Genoa winches</b> 2 x Harken 46.2 self-tailing winches	-	■	-
	<b>Genoa winches</b> 2 x Harken 60.2 self-tailing winches	-	-	■
	<b>Coachroof winches</b> 2 x Harken 40.2 self-tailing winches	■	■	-
	<b>Coachroof winches</b> 2 x Harken 44.2 self-tailing winches	-	-	■
	<b>Electric genoa winches</b> 2 x Harken 44.2 STCE-H 12v self-tailing in place of standard winches	□	-	-
	<b>Electric genoa winches</b> 2 x Harken 46.2 STCE-H 12v self-tailing in place of standard winches	-	□	-
	<b>Electric genoa winches</b> 2 x Harken 60.2 STCE-H 12v self-tailing in place of standard winches	-	-	□
	<b>Electric coachroof winch</b> 1 x Harken 40.2 STCE-H 12v self-tailing in place of standard winch to port	□	□	-
<b>Electric coachroof winch</b> 1 x Harken 44.2 STCE-H 12v self-tailing in place of standard winch to port	-	-	□	
Sail Handling	<b>Genoa tracks</b> adjustable Harken lead cars	■	■	-
	<b>Genoa tracks</b> adjustable Harken lead cars with control line lead aft to cockpit	-	-	■
	<b>Winch handles</b> 2 x Harken handles with ball-bearing grip	■	■	■
	<b>Line jammers</b> Spinlock, on both sides of coachroof with Harken return blocks	■	■	■
	<b>Mainsheet traveller</b> long, roof-mounted Harken traveller with ball-bearing cars, control lines lead aft to cockpit	■	■	■
	<b>Padeyes</b> Wichard for spinnaker turning blocks, tweaker lines, pole downhaul	■	■	■
	<b>Spinnaker deck hardware</b> triple Spinlock jammer to starboard, 3-sheave return block on deck, 2 additional folding Wichard padeyes on side decks	-	-	□
	<b>Asymmetrical spinnaker gear</b> halyard, 2 sheets, tack line lead forward on deck, removable bowsprit on foredeck, Harken blocks	□	□	□
<b>Symmetrical spinnaker gear</b> halyard, 2 sheets, 2 guys, pole uphaul and downhaul, spinnaker pole and adjustable car for mast, Harken blocks	□	□	□	
Mast and Rigging	<b>Furling mast</b> SELDEN aluminium with double spreaders, spinnaker track mounted forward	■	■	-
	<b>Furling mast</b> SPARCRAFT aluminium with double spreaders, spinnaker track mounted forward	-	-	■
	<b>Standing rigging</b> discontinuous 1x19 stainless steel wire	■	■	■
	<b>Backstay</b> fixed, double	■	■	■
	<b>Genoa furler</b> with attachment to stemhead fitting and furling line lead aft to roof winch (Facnor on 39DS and 42DS, Profurl on 49DS)	■	■	■
	<b>Running rigging</b> polyester topping lift, mainsail halyard, genoa halyard, mainsheet, genoa sheets	■	■	■
	<b>Rigid boom vang</b> with gas cylinder and control line lead aft to the cockpit	■	■	■
	<b>Windex 15</b> wind indicator for masthead	■	■	■
<b>Releasable forestay</b> for storm sail, attaches to padeye behind the anchor locker stay is equipped with quick release and adjustment mechanism, inner stay is attached to a padeye on starboard side deck when not in use	-	-	□	
Cockpit	<b>Teak inlay</b> on seating area, transom and transom steps	■	■	■
	<b>Teak cockpit</b> floor inlay	□	□	■
	<b>Teak side decks</b> hand-laid teak side decks	□	□	□
	<b>Cockpit lockers</b> 1 locker under bench seat to port and lazarette locker to port under the helm seats for technical access to steering system	■	-	-
	<b>Cockpit lockers</b> 2 lockers under bench seats and lazarette locker to port under the helm seats for technical access to steering system	-	■	-
	<b>Cockpit lockers</b> 2 lockers under bench seats and 2 lazarette lockers under the helm seats for technical access to steering system	-	-	■
	<b>Cockpit table</b> folding injected fibreglass table with storage, cup holders, bottle holders, stainless steel handrail, courtesy lighting, 12v plug	■	■	■
	<b>Teak cockpit table</b> with all the same functions of above, but with teak leaves and top, Sunbrella® Captain Navy cover	□	□	□
	<b>Gas locker room</b> for 2 gas bottles with connection to gas system and cut-off valve under stove in the galley	■	■	■
	<b>Wet locker</b> under teak grating between helm positions for liferaft storage	-	-	■
	<b>Wheels</b> 2 leather-covered steering wheels and compasses at each helm station	■	■	■
	<b>Steering wheel covers</b> Sunbrella® Captain Navy blue with zips for easy removal	□	□	□
	<b>Transom gate</b> double fibreglass doors that can be secured when open or closed	-	-	■
	<b>Instrumentation</b> dedicated space for instruments within easy reach of helm positions, room for GPS chartplotter mounted at aft end of cockpit table with easy viewing from each helm	■	■	■
	<b>Engine controls</b> throttle and engine control panel mounted at starboard helm, engine panel includes fuel gauge, RPM gauge, warning lights, ignition	■	■	■
	<b>Swim ladder</b> stainless steel folding ladder mounted on swim platform	■	■	-
	<b>Swim ladder</b> stainless steel with teak steps integrated into dedicated compartment under transom step	-	-	■
	<b>Cockpit shower</b> retractable cold water shower with tap	-	-	-
	<b>Cockpit shower</b> retractable hot and cold water shower with tap	■	■	■
	<b>Cockpit cushions</b> Sunbrella® Captain Navy cushions for seating area with attachment clips	□	□	□
<b>Cockpit bimini</b> Sunbrella® Captain Navy with stainless steel bows, retractable with storage cover	□	□	□	
<b>Cockpit sprayhood</b> wide Sunbrella® Captain Navy with vinyl windscreen with zip-out middle window for ventilation, retractable	□	□	□	
<b>Anchor locker</b> forward, lockable, room for anchor and tackle, integrated windlass area, holder for windlass handle	■	■	■	
<b>Deep sail locker</b> forward, accessible via opening deck hatch with lock and ventilation, stainless steel ladder, lighting, access to windlass controls	-	-	■	
Deck Hardware	<b>Bow pulpit</b> open, stainless steel with teak step, navigation lights and integrated wiring for lights	■	■	■
	<b>Stern pulpits</b> stainless steel with buoy bracket	■	■	■
	<b>Outboard engine bracket</b> for stern pulpit	□	□	□
	<b>Windlass</b> Quick 1000W combination rope 18mm and chain 10mm, vertical-mounted in the anchor locker, hand-held remote, manual handle	■	■	-
	<b>Windlass</b> LEWMAR 1500W combination rope 18mm and chain 10mm, vertical-mounted in the anchor locker with above-deck line drum, hand-held remote, manual handle	-	-	■
	<b>Windlass control</b> second windlass control mounted in cockpit with chain counter for easy, short-handed anchoring	-	-	□
	<b>Anchor roller</b> double stainless steel fitting with swivelling self-launching roller for hands-free launching and retrieving for tackle	■	■	■
	<b>Anchoring kit</b> fluke anchor 16kg with 25 meters of 10mm chain and 38 meters of 16mm line	□	-	-
	<b>Anchoring kit</b> fluke anchor 20kg with 32 meters of 10mm chain and 50 meters of 18mm line	-	□	□
	<b>Lifelines</b> double level of stainless steel lifelines with PVC coating and stainless steel stanchions	■	■	■
	<b>Luxury deck fittings</b> chrome compasses bases, dorade vents and turnbuckle covers	-	-	□
	<b>Lifeline gates</b> opening gates on each side	■	■	■
	<b>Toerail</b> teak profile with integrated chrome chocks and drainage for side deck	■	■	■

		SO 39 DS	SO 42 DS	SO 49 DS
Deck Hardware	<b>Cleats</b> 4 x aluminium mooring cleats	■	■	-
	<b>Cleats</b> 6 x chrome mooring cleats	-	-	■
	<b>Midship cleats</b> 2 x aluminium mooring cleats mounted on side decks near chocks	□	□	-
	<b>Teak rubrail</b> for hull protection	-	-	□
	<b>Mooring kit</b> 6 fenders and 3 x 20 meter docklines	□	□	□
<b>Handrails</b> sculpted, long stainless steel handrails on coachroof for secure movement forward	■	■	■	

Technical features and options		SO 39 DS	SO 42 DS	SO 49 DS
Construction	<b>Deck</b> Prisma Process® injected deck, ISO gelcoat surface, discontinuous balsa block coring	■	■	-
	<b>Deck</b> hand-laid fibreglass deck, ISO gelcoat surface, discontinuous balsa block coring, interior fibreglass deck counter mould	-	-	■
	<b>Hull</b> solid, hand-laid fibreglass, ISO glecoat surface, vinylester resin in outer skin to protect against osmosis	■	■	■
	<b>Kevlar®</b> reinforcement in hull laminate	-	-	■
	<b>Structure</b> 3 <sup>rd</sup> generation inner fibreglass grid, high-load zones cut out and relaminated, drainage system through structure, special emergency repair zone in keel area	■	■	-
<b>Structure</b> wood stringers glassed to the hull and encased in fibreglass, drainage system through structure	-	-	■	
Lighting	Flush mounted chromed brass ceiling lights in saloon, head compartments and cabins	■	■	■
	On/off switches in saloon for overhead lights	-	-	■
	Indirect halogen lighting under side decks in saloon and head compartments	■	■	■
	Gooseneck chart light mounted at nav station	■	■	-
	Red/white combination light for night vision at nav station	-	-	■
Electrical	12v alternator output	60 A	80 A	80 A
	Charge distributor/isolator	■	■	■
	Engine start battery capacity (*Dryfit high-performance batteries standard on Sun Odyssey 49DS)	110 Ah	110 Ah	80 Ah*
	Domestic battery bank capacity (*Dryfit high-performance batteries standard on Sun Odyssey 49DS)	220 Ah	220 Ah	240 Ah*
	Extra 110Ah domestic battery (extra Dryfit high-performance battery 80Ah on Sun Odyssey 49DS)	□	□	□
	Positive battery switch for engine bank, positive battery switch for domestic bank and negative general cut-off switch	■	■	■
	115v shore power inlet with differential breaker	■	■	■
	40A battery charger, multi-phase	■	■	-
	60A battery charger, multi-phase	-	-	■
	Electrical panel with 12v breakers, 115v breakers, 12v ammeter, 12v consumption meter, 12v charging meter	■	■	■
	One 115v and 12v plug per cabin, 115v plugs in galley, saloon and nav station	■	■	■
	115v stainless steel microwave	□	□	□
	Generator 4kw ONAN 115v located in fully-soundproofed, compartment at base of companionway, power selector switch and generator control panel located at nav station, exhaust separator with below waterline discharge for silent operation	-	-	□
Plumbing	Hot and cold pressurised water distributed through-out the boat via semi-rigid hose	■	■	■
	"Heavy-duty" water pump and accumulator tank for consistent water pressure	■	■	■
	10 Usgal hot water tank that is connected to engine heat exchanger and to 115v electrical system	■	■	■
	Chromed shower faucets in washrooms	■	■	■
	Digital water meter at electrical panel to accurately gauge water use aboard	■	■	■
	Shower sumps equipped with individual electric pumps with filters and on-off switches	■	■	■
	Large manual pump marine toilets	■	■	■
	Jabsco electric Quiet-Flush toilets in place of standard, available for each head compartment	-	-	□
	12 Usgal holding tank with gravity drain and deck fitting for forward head compartments (aft port head equipped with standard tank), available for each head compartment	-	■	■
	Yanmar 3JH4E <b>40 HP</b> , 29.4Kw latest generation of environmentally friendly engines	■	-	-
Yanmar 4JH4E <b>54 HP</b> , 39.6Kw latest generation of environmentally friendly engines	-	■	-	
Yanmar 4JH3 TE <b>75 HP</b> , 55Kw, turbocharged, latest generation of environmentally friendly engines	-	-	■	
Yanmar 4JH3 HTE <b>100 HP</b> , 73.6Kw, turbocharged with intercooler, latest generation of environmentally friendly engines	-	-	□	
Fully soundproofed engine compartment with engine access behind stairwell and from aft cabin	■	■	■	
Stainless steel propeller shaft with a fixed 3-blade bronze propeller	■	■	■	
Fuell/water separator	■	■	■	
Built-in muffler, forced air ventilation and stainless steel exhaust fitting aft	■	■	■	
Max-Prop 3-blade feathering propeller adds performance under power, low-speed manoeuvring, backing and less drag under sail	-	-	□	
Bow thrusters	□	□	□	
Line cutting collar on shaft for extra protection against fouling	□	□	□	

Comfort features and options		SO 39 DS	SO 42 DS	SO 49 DS
Comfort features and options	<b>Fixed hull ports</b> with track-mounted curtains	4	4	4
	<b>Opening cockpit and roof ports</b> with curtains	6	5	4
	<b>Opening deck hatches</b> forward-facing with sun blinds integrated into headliner	4	5	10
	<b>Insect screens on deck hatches</b>	■	■	-
	<b>CD/radio player</b> in saloon with 2 speakers in saloon	■	■	■
	<b>CD/radio player</b> compatible with MP3 format disks in saloon in place of standard CD/radio player	-	-	□
	<b>TV LCD 15"</b> in saloon, <b>DVD player</b> in saloon, <b>Washer/Dryer</b> 5kg 115v installed under nav station seat	-	-	-
	<b>Cockpit speakers</b> watertight	□	□	□
	<b>Air Conditioning</b> 115v 12000 BTU unit installed under saloon seating, vents in saloon and forward and aft cabins control panel and thermostat	□	□	-
	<b>Air Conditioning</b> 115v 19000 BTU unit installed under saloon seating and in aft locker, vents in saloon and forward and aft cabins control panel and thermostat	-	□	-
	<b>Air Conditioning</b> 115v 32000 BTU 4 units separately controlled and regulated and vents in saloon, forward and aft cabins	-	-	□
	<b>Forced air heating</b> 1 unit 5000 BTU Webasto® diesel heater installed in cockpit lazarette, vents in forward and aft cabins, saloon and head compartments	□	□	-
	<b>Forced air heating</b> 1 unit 5000 BTU and 1 unit 3500 Webasto® diesel heaters installed in cockpit lockers, vents in forward and aft cabin, saloon and head compartments	-	-	□

		SO 39 DS	SO 42 DS	SO 49 DS		
		2C/1H	2C/2H	2C/2H	3C/2H	4C/3H
Wood	<b>Fine Teak® interior</b> laminated panels with solid Moabi trim around galley, companionway and cabinetry, finished in satin UV stabilised varnish	■	■	-	-	-
	<b>Teak interior</b> teak laminated panels with solid teak trim around galley, companionway and cabinetry, finished in satin UV stabilised varnish	-	-	■	■	■
	<b>Teak floorboards</b> teak laminated floorboards with light-coloured lines, finished in satin UV stabilised varnish	-	-	■	■	■
	<b>Laminate floorboards</b> with light-coloured lines, varnished edges	■	■	-	-	-
Forward owner's cabin	<b>Forward owner's cabin</b> with central berth	■	■	■	■	-
	Double berth, high-density foam mattress (PREMIUM mattress standard on 49DS)	6'7"x6'	6'7"x6'	6'7"x5'5"	6'7"x5'5"	-
	Mattress battens under high-density foam mattress for increased comfort	-	-	□	□	-
	Storage under berth	■	■	■	■	-
	Deep cabinet with shelves and hanging rod	■	■	■	■	-
	Vanity in forward cabin with desk, mirror, and lighting	-	-	■	■	-
	Wood hull liner	■	■	■	■	-
	Private forward owner's head compartment with sink, clothes hook, mirror, towel holder, toilet paper holder, wastebasket, cabinet above sink, shower sump with grate and electric drainage pump	-	■	-	-	-
	Private forward owner's head compartment with sink, separate shower, clothes hook, mirror, towel holder, toilet paper holder, wastebasket, cabinet above sink, folding seat over toilet and shower sump with grate and electric drainage pump	-	-	■	■	-
	<b>Twin forward cabins</b> transformable into single cabin by easily removable longitudinal bulkhead, storage for bulkhead under berth	-	-	-	-	■
	double berths with PREMIUM mattresses	-	-	-	-	2x 6'7"x4'4"
	Storage drawers under berth	-	-	-	-	■
	Deep cabinet with shelves and hanging rod per cabin	-	-	-	-	■
	Fabric hull liner	-	-	-	-	■
	2 head compartments forward with sink, shower, clothes hook, mirror, towel holder, toilet paper holder, wastebasket, cabinet above sink and shower sump with grate and electric drainage pump	-	-	-	-	■
	Aft owner's cabin	<b>Aft owner's cabin</b> with reading lights at head of berth	■	■	■	-
Transversal double berth with teak trim and padded cushion serves as backrest and headboard, high-density foam mattress		6'4"x6'4"	-	-	-	-
Central double berth with teak trim and padded headboard, high-density foam mattress (PREMIUM mattress standard on 49ds)		-	6'4"x6'4"	6'4"x6'4"	-	-
Mattress battens under high-density foam mattress for increased comfort		-	-	□	-	-
Deep cabinet with shelves and hanging rod		■	■	■	-	-
Seating to either side of the berth with fabric cushions that match saloon fabrics		-	■	■	-	-
Wooden hull liner		■	■	■	-	-
Large head compartment accessible from saloon with sink, separate shower, clothes hook, mirror, towel holder, toilet paper holder, wastebasket, cabinet above sink and shower sump with grate and electric drainage pump		■	■	■	-	-
<b>Twin aft cabins</b> transformable into single cabin by easily removable longitudinal bulkhead, storage for bulkhead under berth		-	-	-	■	■
Double berths with PREMIUM mattresses		-	-	-	2x6'4"x5'5"	2x6'4"x5'5"
Deep cabinet with shelves and hanging rod per cabin		-	-	-	■	■
Teak hull liner		-	-	-	■	■
Large head compartment accessible from saloon or aft cabin with sink, separate shower, clothes hook, mirror, towel holder, toilet paper holder, wastebasket, cabinet above sink and shower sump with grate and electric drainage pump	-	-	-	■	■	
Navigation station	<b>Navigation station</b> full-function with general electrical panel, room for the latest in GPS chartplotters and bookshelf	■	■	■	■	■
	Forward-facing navigation desk with curved nav seat and storage underneath	■	■	■	■	■
	Deep navigation desk with storage	■	■	■	■	■
Saloon	<b>Saloon</b> with U-shaped seating area to starboard, wrap-around cushions and storage under seating area	■	■	■	■	■
	Saloon dining table with fiddles, removable pedestal legs	■	■	■	■	■
	Cushion to fit over saloon table and support beams to turn standard table into a double berth	□	□	□	□	□
	Deluxe saloon table with fixed storage base, inlaid table top, and folding leaves	□	□	□	□	□
	Extension for saloon table	□	-	-	-	-
	2 removable wooden stools with tiedowns and cushions facing table	-	□	-	-	-
	Fixed bench seat facing table with cushion	-	-	□	□	□
	2 removable luxury armchairs with tiedowns for saloon	-	-	□	□	□
	Upper storage cabinets	■	■	■	■	■
	Lounge seating to port with plush cushions and upper storage cabinets	■	■	■	■	■
Companionway with curved wood steps and non-slip strips	■	■	■	■	■	
Galley	<b>Galley</b> with double sinks with covers and reversible cutting board, chrome plumbing fittings, storage cabinets and drawers	■	■	■	■	■
	L-galley to port with glass separator between galley counter and seating area	■	■	■	■	■
	Antium high-quality resin countertop	-	-	■	■	■
	Foot pump for fresh or saltwater with separate faucet, valve under sink	-	-	■	■	■
	Gimballed 2-burner stove with oven with stainless steel protection bar	-	-	-	-	-
	Luxury 2-burner stove with black finish, wood handle, stainless steel oven/broiler	■	■	■	-	-
	4-burner stainless steel stove with thermostatically controlled oven and stainless steel protection bar, in place of regular stove/oven unit	-	-	■	■	■
	Single fridge box with freezer area, wire baskets, interior lighting comes on when door opened, 12v refrigeration and integrated compressor	■	■	-	-	-
	Double fridge box, top-loading with 2 opening lids and gas lifts, storage bins, 12v refrigeration in large box and compressor under the stove	-	-	■	■	■
	12v freezer unit for smaller fridge box with separate compressor and "keel cooler" unit to eliminate fan noise and increase efficiency of the unit	-	-	□	□	□
Stainless steel vertical access door to large fridge box, includes wire shelving inside fridge box for increased storage	-	-	□	□	□	
Headroom	Forward cabin (s)	6'	6'4"	6'2"		
	Aft cabin (s)	6'4"	6'8"	6'8"		
	Companionway	6'5"	6'6"	6'3"		
	Saloon	6'4"	6'6"	6'8"		
	Galley	6'4"	6'6"	6'8"		

423 894 310 RCS La Roche sur Yon. Simplified inventory. This document is non contractual and we reserve the right to modify equipment or specification without advance notice. Updated september 2006. MORGANE - Les Herbiers