

Sun Odyssey 36i

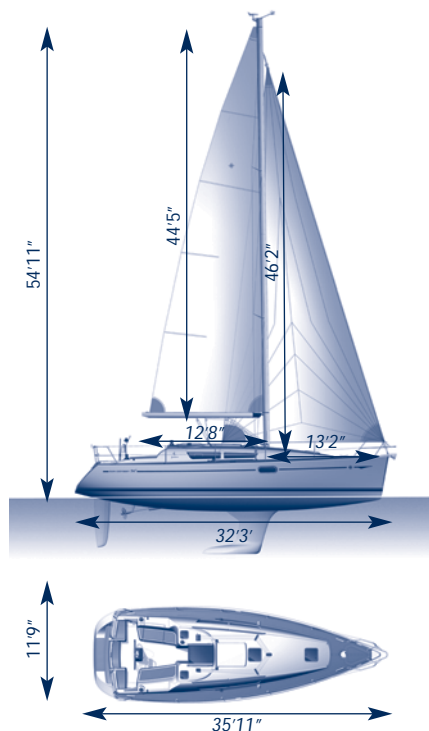

Sun Odyssey 36i Performance

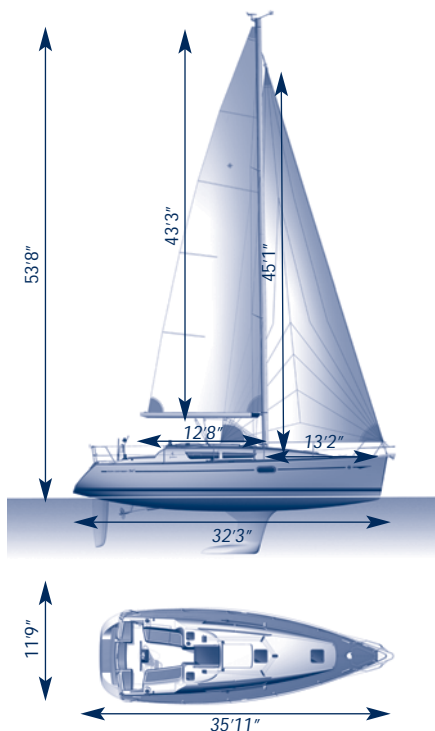

Certification conform with CE regulation.

	SO 36i	SO 36i Performance
Overall length	35'11"	35'11"
Hull length	35'1"	35'1"
Waterline length	32'3"	32'3"
Beam	11'9"	11'9"
Displacement <i>light load with deep draft keel</i>	12566 lbs	12566 lbs
Standard draft <i>cast iron fin keel with elongated bulb and exterior epoxy barrier coat</i>	6'4"	6'4"
Standard keel weight	3463 lbs	3463 lbs
Shoal draft <i>cast iron fin keel with elongated bulb and exterior epoxy barrier coat</i>	4'10"	-
Shoal keel weight	3985 lbs	-
Performance keel draft <i>cast iron fin keel with elongated bulb and exterior epoxy barrier coat, profiled leading and trailing edges</i>	-	6'9"
Performance keel weight	-	3408 lbs
CE category	A8/B10/C12	A8/B10/C12
Architect/designer	M.Lombard	M.Lombard
Water capacity <i>2 rotomolded tanks located under forward and aft berths with separate deck fills</i>	94 Usgal	94 Usgal
Fuel <i>rotomolded tank located under aft berth with deck fill</i>	34 Usgal	34 Usgal
Holding tank <i>rotomolded tank located in head compartment with valve for overboard discharge via gravity and deck fitting for pump out</i>	13 Usgal	13 Usgal
Fridge <i>compartment with vertical access</i>	47 Usgal	47 Usgal

Sails	SO 36i	SO 36i Performance
Classic mainsail <i>80% battened, polyester sailcloth, Rutgerson® stainless steel eyes and 2 reinforced reef points with auto reef</i>	330 sqft	-
Furling genoa <i>130% high-tenacity Dacron cloth, Sunbrella® UV luff protection, Rutgerson® stainless steel eyes</i>	355 sqft	-
Performance mainsail <i>, semi-full batten, Prestige series tri-radial with sandwich construction of double taffeta layers and Mylar for form stability, 2 automatic reefs</i>	-	333 sqft
Performance furling genoa <i>135% tri-radial Prestige series with sandwich constructions of double taffeta layers and Mylar for form stability and Sunbrella® UV luff protection, Rutgerson® stainless steel eyes</i>	-	409 sqft
Furling mainsail (optional) <i>polyester sailcloth, UV luff protection, Rutgerson® stainless steel eyes</i>	252 sqft	-
Spinnaker <i>optimal size for boat (not available from Jeanneau)</i>	968 sqft	1054 sqft
Total sail area <i>for standard mast and sails</i>	685 sqft	742 sqft

■ Standard □ Option - Not available

	SO 36i	SO 36i Performance	
Sail Handling	Lazy bag in Sunrella® Captain Navy fabric with integrated lazy jacks	■	■
	Coachroof winch to port 1 x Harken 35.2 self-tailing winch	■	■
	Genoa winches 2 x Harken 40.2 self-tailing winches	■	■
	Harken genoa tracks adjustable lead cars	■	-
	Harken genoa tracks adjustable lead cars with control lines lead aft to cockpit	-	■
	Winch handles 2 x Harken handles with ball-bearing grip	■	■
	Line jammers Spinlock, on coachroof	■	■
	Mainsheet traveller roof-mounted Harken traveller with ball-bearing cars, control lines lead aft to cockpit	■	■
	Spinnaker deck hardware coachroof winch Harken 35.2 to star board, triple Spinlock jammer, 5 padeyes and 1 bullet lead	■	■
	Asymmetrical spinnaker gear halyard, 2 sheets, tack line lead forward on deck, removable bowsprit on foredeck, and necessary blocks	□	□
Symmetrical spinnaker gear halyard, 2 sheets, pole uphaul and downhaul, spinnaker pole, and necessary blocks	□	□	
Mast and Rigging	Classic mast SELDEN aluminium with double spreaders, deck-stepped	■	-
	Performance classic mast SELDEN aluminium with double spreaders, deck-stepped	-	■
	Standing rigging discontinuous 1x19 stainless steel wire	■	-
	Standing rigging discontinuous Dyform® stainless steel wire	-	■
	Backstay fixed	■	-
	Backstay adjustable via a block and tackle system	-	■
	Genoa furler Facnor® furler with attachment to stemhead fitting and furling line lead aft to roof winch	■	-
	Genoa furler Facnor® racing series with removable drum, double sail slot and aerodynamic profile, mounted to stemhead fittings furling line lead aft to roof winch	-	■
	Running rigging polyester topping lift, mainsail halyard, genoa halyard, mainsheet, genoa sheets	■	-
	Running rigging Dyneema® mainsail halyard, genoa halyard, mainsheet, genoa sheets	-	■
	Boom vang block and tackle system	■	-
Rigid boom vang	-	■	
Cockpit & Deck Storage	Wood inlay on cockpit bench seating	■	■
	Wood cockpit floor inlay	□	□
	Cockpit lockers 1 locker under port bench seat and 1 lazarette locker under the port helm seat	■	■
	Gas locker for 2 bottles with connection to gas system and cut-off valve under stove in the galley	■	■
	Liferaft locker located in dedicated compartment between helm seats	■	■
	Cockpit table plastic, mounted on stainless steel base, cup holders	□	□
	Wheel steering leather-covered steering wheel mounted on steering pedestal with grabrail and pod for instrumentation	■	■
	Steering wheel large diameter removable Steer'n-Go 1200 mm diameter with storage bracket on stern pulpit includes Sunbrella® Captain Navy wheel cover	□	□
	Compass mounted on steering pedestal	■	■
	Steering wheel cover Sunbrella® Captain Navy blue with zip for easy removal	□	□
	Engine controls throttle and engine control panel, warning lights, ignition protected by a plexiglass panel	■	■
	Swim ladder stainless steel folding ladder mounted on transom step	■	■
	Cockpit shower retractable cold water shower with tap	■	■
Cockpit shower retractable hot and cold water shower with tap	□	□	
Anchor locker forward, room for anchor and tackle	■	■	
Deck Hardware	Bow pulpit open, stainless steel with navigation lights and integrated wiring for lights	■	■
	Stern pulpits stainless steel with buoy bracket	■	■
	Outboard engine bracket mounted on stern pulpit	□	□
	Windlass mechanical windlass, vertical	■	■
	Windlass Quick 1000W combination rope and chain 10mm, vertical-mounted in the anchor locker, hand-held remote, manual handle, with swivelling self-launching roller for hands-free launching and retrieving for tackle	□	□
	Anchor roller double roller	■	■
	Anchoring kit Delta anchor 16 kg with 28 meters of 10 mm chain and 40 meters of 18 mm line	□	□
	Lifelines double level of stainless steel lifelines, stainless steel stanchions	■	■
	Lifeline gates opening gates on each side	□	□
	Toerail wood profile with integrated chrome chocks and drainage for side deck	■	■
	Midship chocks	■	■
	Cleats 4 x aluminium mooring cleats forward and aft	■	■
	Midship cleats 2 x aluminium cleats placed midship near midship chocks	■	■
	Mooring kit 6 fenders and 4 docklines	□	□
Handrails sculpted, long wood handrails on coachroof for secure movement forward	■	■	

■ Standard □ Option - Not available

		SO 36i	SO 36i Performance
Construction	Deck Prisma Process® injected deck, ISO gelcoat surface, discontinuous balsa block coring	■	■
	Hull solid, hand-laid fibreglass, ISO gelcoat surface, protective barrier coat	■	■
	Structure inner fibreglass grid, high-load zones cut out, drainage system through structure	■	■
Lighting	LED navigation lights and anchor lights	■	■
	Flush mounted chromed brass LED ceiling lights in saloon, head compartments and cabins	■	■
	Indirect halogen lighting under side decks in saloon and head compartments	■	■
	Gooseneck chart light mounted at nav station	■	■
Electrical Circuit	12 v alternator output	55 A	55 A
	Charge distributor/isolator	■	■
	Engine start battery capacity	70 Ah	70 Ah
	Domestic battery bank capacity	70 Ah	70 Ah
	Extra 70 Ah domestic battery	■	■
	Battery switches for engine bank, positive battery switch for domestic bank and negative general cut-off switch	■	■
	110 v shore power inlet with differential breaker, one 110 v plug per cabin, galley and saloon + 25 A charger	■	■
	Electrical panel with 12 v breakers	■	■
Plumbing	Pressurised water distributed through-out the boat via semi-rigid hose	■	■
	"Heavy-duty" water pump and accumulator tank for consistent water pressure	■	■
	11 Usgal hot water tank that is connected to engine heat exchanger and 110 v system (when 110 v shorepower system fitted)	■	■
	Chromed shower faucets in washroom	■	■
	Digital water meter to accurately gauge water use aboard	■	■
	Shower sumps equipped with individual electric pumps with filters and on-off switches	■	■
	Manual pump marine toilets	■	■
Engine	Yanmar 3YM30 29 HP, 21.3Kw with heat exchanger, latest generation of environmentally friendly engines	■	■
	Fully soundproofed engine compartment with engine access behind stairwell and from aft cabin	■	■
	Stainless steel propeller shaft 25mm diameter with maintenance free stuffing box	■	■
	Fuel/water separator	■	■
	Built-in muffler, air ventilation and stainless steel exhaust fitting aft	■	■
	Fixed 3-blade bronze propeller	■	-
	Feathering propeller, 3-blade, Flex-o-Fold	-	■
	Line cutting collar on shaft for extra protection against fouling	□	□

Comfort features and options	Fixed hull ports with curtains	2	2
	Opening cockpit and roof ports with curtains	4	4
	Opening deck hatches	4	4
	Combination shade/insect screens for deck hatches	■	■
	CD/radio MP3 player in saloon	□	□
	Stereo speakers in saloon	■	■
	Cockpit speakers watertight	□	□
	Forced air heating 1 unit 5500 BTU Webasto® diesel heater installed in cockpit lazarette, vents in forward cabin, aft cabin and saloon	□	□

■ Standard □ Option - Not available

		SO36i		
		2C/1H	3C/1H	
Interior features and options	Wood	Fine Teak® laminated panels with solid wood trim around galley, companionway and cabinetry, finished in satin UV stabilised varnish	■	■
		Laminate floorboards laminated floorboards with light-coloured lines and sealed edges	■	■
	Forward owners cabin	Forward owner's cabin with V-berth	■	■
		Double berth with high-density foam mattress	6'8" x 5'10"	6'8" x 5'10"
		Storage locker under berth	■	■
		Deep cabinet with shelves and hanging rod	■	■
		White vinyl lining on hull with lateral wood shelf	■	■
	Aft owners cabin	Aft owner's cabin	■	-
		Double berth with high-density foam mattress	6'7" x 5'9"	-
		Deep cabinet with shelves and hanging rod	■	-
		White vinyl lining on hull with lateral wood shelf	■	-
		Large head compartment accessible from saloon with sink, separate plexiglass shower, clothes hook, mirror, towel holder, toilet paper holder, cabinet above sink and shower sump with grate and electric drainage pump	■	-
		Twin aft cabins	-	■
		Double berths, high-density foam	-	6'7" x 4'10"
		Deep cabinet with shelves and hanging rod per cabin	-	■
		White vinyl lining on hull with lateral wood shelf	-	■
		Head compartment accessible from saloon with sink, storage cabinet, clothes hook, towel holder, toilet paper holder, shower sump with electric drainage pump	-	■
	Navigation station	Locker and technical compartment with access through head compartment, storage baskets, lighting and lots of extra space for storage under the exterior cockpit locker	■	-
		Navigation station with general electrical panel	■	■
Sliding nav desk that can be placed in forward-facing or aft-facing position for increased seating with curved nav seat and storage underneath		■	■	
Saloon	Deep navigation desk with storage	■	■	
	Saloon with U-shaped seating area, wrap-around cushions and storage under seating area	■	■	
	Fixed saloon table with fiddles	■	■	
	Saloon table with two fold-down leaves, bottle storage and conversion kit for double berth	□	□	
	Storage cabinets along hull sides	■	■	
Galley	Companionway with and wood steps	■	■	
	Galley with laminated countertops, chrome plumbing fittings, storage cabinets and drawers	■	■	
	L-galley to starboard with glass separator between galley counter and seating area, stainless steel double sink	■	■	
	12 v compressor with evaporator plate located in fridge compartment	■	■	
Headroom	Luxury 2-burner stove with black finish, wood handle, stainless steel oven/broiler	■	■	
	Forward cabin		5'11"	
	Aft cabin (s)		6'2"	
	Companionway		6'7"	
	Saloon		6'4"	
Galley		6'2"		

■ Standard □ Option - Not available C = Cabins H = Head

491 372 702 RCS La Roche sur Yon. Simplified inventory. This document is non contractual and we reserve the right to modify equipment or specification without advance notice. Updated October 2010. MORGAME - Les Herbiers



JEANNEAU

