



SUN ODYSSEY 509



Presentation Dossier – July 2011



JEANNEAU

SUN ODYSSEY 509

Key Points:

- **Flagship of the Sun Odyssey range:** Offshore cruiser, elegant and very comfortable.
- **Modern hull** designed by Philippe Briand, that combines a long waterline length and a hard chine for speed and comfort at sea.
- **Sleek deck lines**, safe and ergonomic with flush hatches and integrated running rigging.
- **Sail plan** with a high aspect ratio. Multiple choices including: self-tacking jib, large, overlapping genoa, Code 0, furling mast, etc...
- **Light and luxury down below** with solid wood, mat varnish, polished stainless steel, leather and a full selection of interior fabrics.
- **Lots of personalisation possible:** Different layout versions, sail plans, keels and fabrics makes each boat individual to each sailor.



JEANNEAU

SUN ODYSSEY 509

The flagship:

New flagship of the range. Inspired by the successes of the Sun Odyssey 409 and the Sun Odyssey 439, the Sun Odyssey 509 is a true work of art.

Philippe Briand designed a modern and performance-oriented hull with a hard chine along with elegant and timelessly beautiful deck styling

Inside, the impressive volume and light provides an open and airy feeling.

Attention to detail can be found throughout. Especially in the safety, function and look of each detail.



Hull and Keel: Modern and balanced

- **Philippe Briand design**
- **Deep keel** (2.28m) or shoal (1.73m)
- **Hard chine on hull** creates stability and enhances interior volume
- **Long water line** provides performance under sail and power
- **Moderate freeboard** lends a beautiful and sleek look to the hull along with the 10 hull ports and hard chine.



Sail and rig plans: Sails for every sailor

- **Several sail plans** including self-tacking, furling Overlapping headsails, Code 0, etc...
- **High aspect ration rig** for maximum performance while limiting the loads on the sheets.
- **Inboard shrouds and genoa tracks** allow better trim of the standard or performance sails and easy circulation on the side decks.
- **A below deck furler** in the Performance Plus has aesthetic value and an even higher aspect ratio rig.
- **Code 0** offered as an option for sailing in light wind conditions





JEANNEAU

SUN ODYSSEY 509

Standard version

106% overlapping genoa and classic mainsail - both sails are supplied in Dacron sail cloth

Advantages:

- High-aspect rig for maximum performance
- Easy to handle sail plan
- Versatile and balanced sail plan at all sailing angles

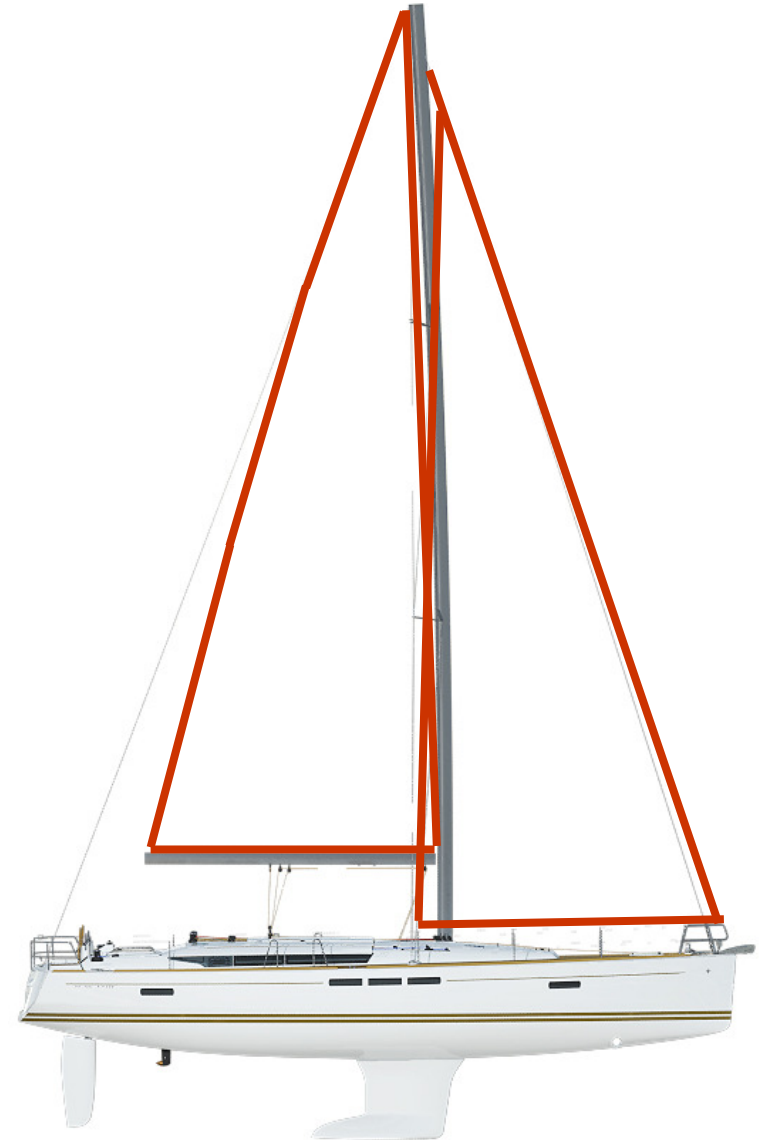



JEANNEAU

SUN ODYSSEY 509

Furling Mast option

106% overlapping genoa and in mast furling mainsail - Both sails are supplied in Dacron sail cloth

Advantages:

- Ease of handling
- Quick furling of the sail
- No hassle reefing

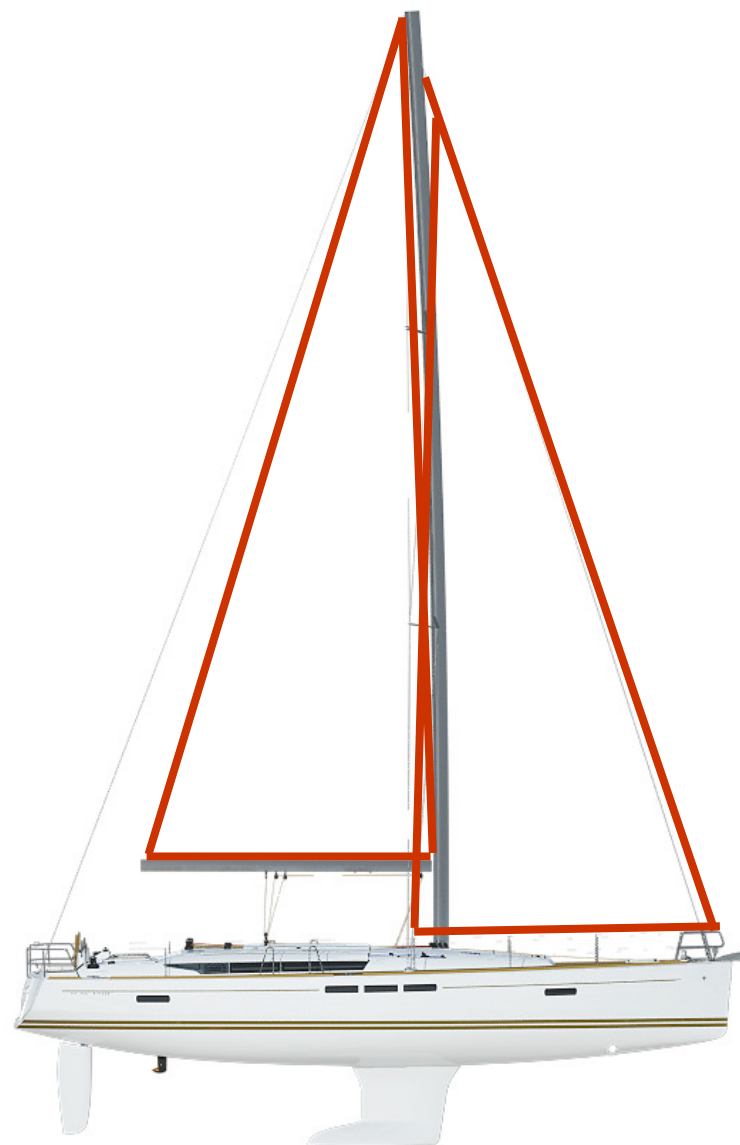



JEANNEAU

SUN ODYSSEY 509

Performance Self-tacking Package

Self-tacking jib and in Performance mainsail - both sails are supplied in cross-cut, tri radial Mylar/taffeta sail cloth

Advantages:

- High-end sail cloth material means less stretch and better performance
- Hands-free tacking
- Great up-wind performance
- Perfect for short-handed sailing

Package also includes:

- Dyform standing rigging
- Dyneema running rigging
- Flex-o-Fold folding 3-blade propeller
- Self-tacking track in front of the mast

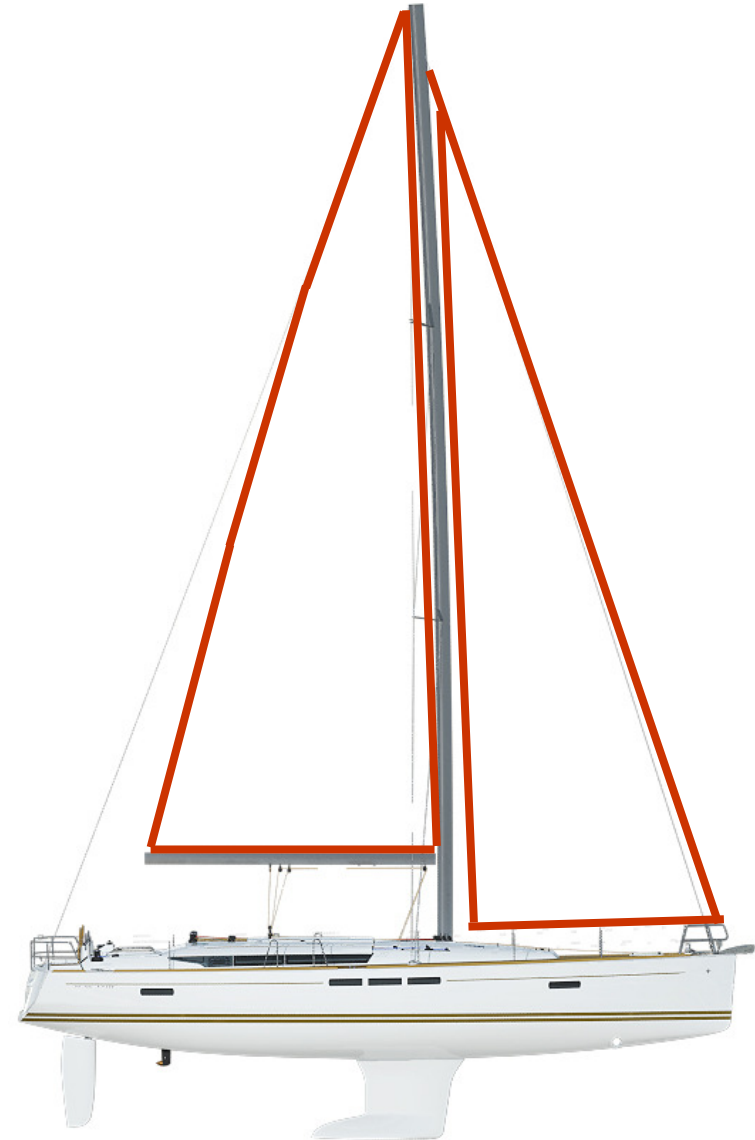



JEANNEAU

SUN ODYSSEY 509

Performance Plus Package

Performance 140% Genoa and Performance mainsail - both sails are supplied in cross-cut, tri radial Mylar/taffeta sail cloth

Advantages:

- High-end sail cloth material means less stretch and better performance
- Maximum sail area for the performance sailor
- Powerful sail plan in light winds
- Ideal for passage making

Package also includes:

- Dyform standing rigging
- Dyneema running rigging
- Flex-o-Fold folding 3-blade propeller
- Ball-bearing genoa sheeting cars adjustable from the cockpit

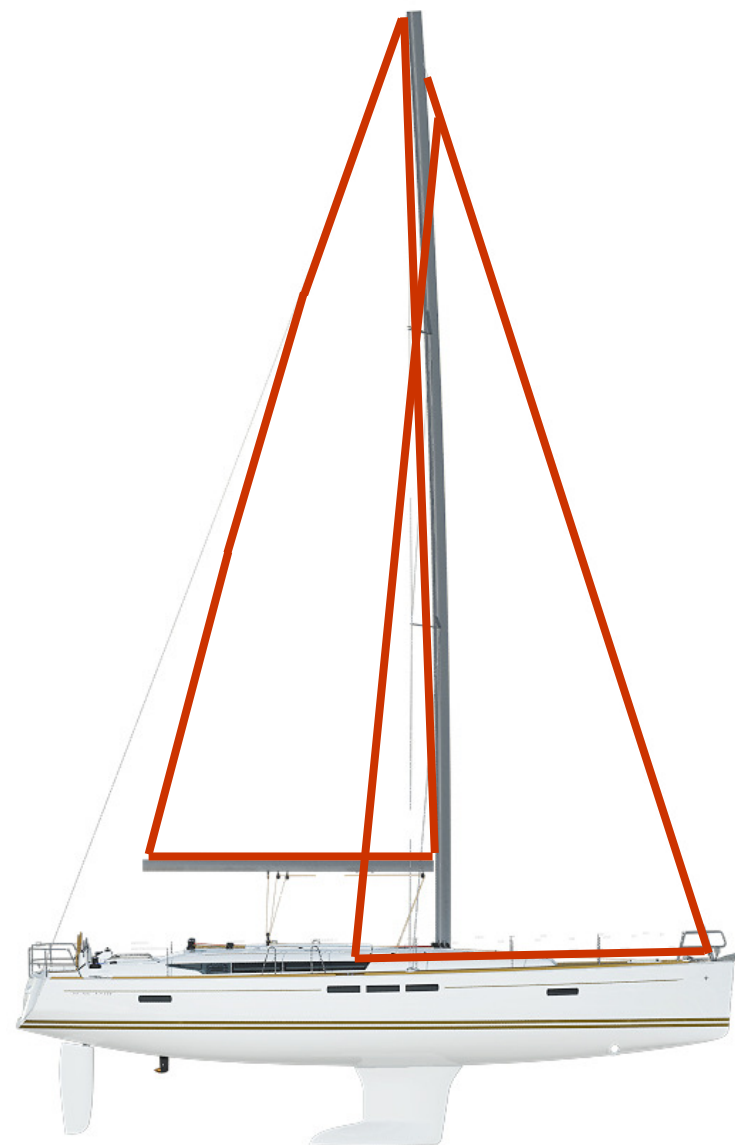



JEANNEAU

SUN ODYSSEY 509





JEANNEAU

SUN ODYSSEY 509

Deck and Cockpit: Liveability, comfort and safety:

- **Twin helm steering moved far aft**, keeps the cockpit clear and gives easy access to the transom
- **Harken deck hardware**: winches, blocks, tracks designed to make sail handling ease from the helm
- **Easy access to the sea** thanks to a wide drop-down aft platform.
- **Large cockpit table** with storage, lighting, icebox, place for instruments and the joystick of the optional 360 Docking system.
- **Flush hatches and integrated running rigging** gives the deck a sleek look and makes movements onboard safer.
- **Lots of storage**: 2 lateral lockers, 2 large lockers under the helm stations, 1 large locker for the optional generator. Forward sail locker and deep anchor locker.





JEANNEAU

SUN ODYSSEY 509





JEANNEAU

SUN ODYSSEY 509



2 part door on hinges

Large table with storage

Flush hatches and integrated running rigging

Harken deck hardware

Twin helms with place for optional GPS screens

Numerous storage compartments and lockers

Wide drop down platform



JEANNEAU

SUN ODYSSEY 509

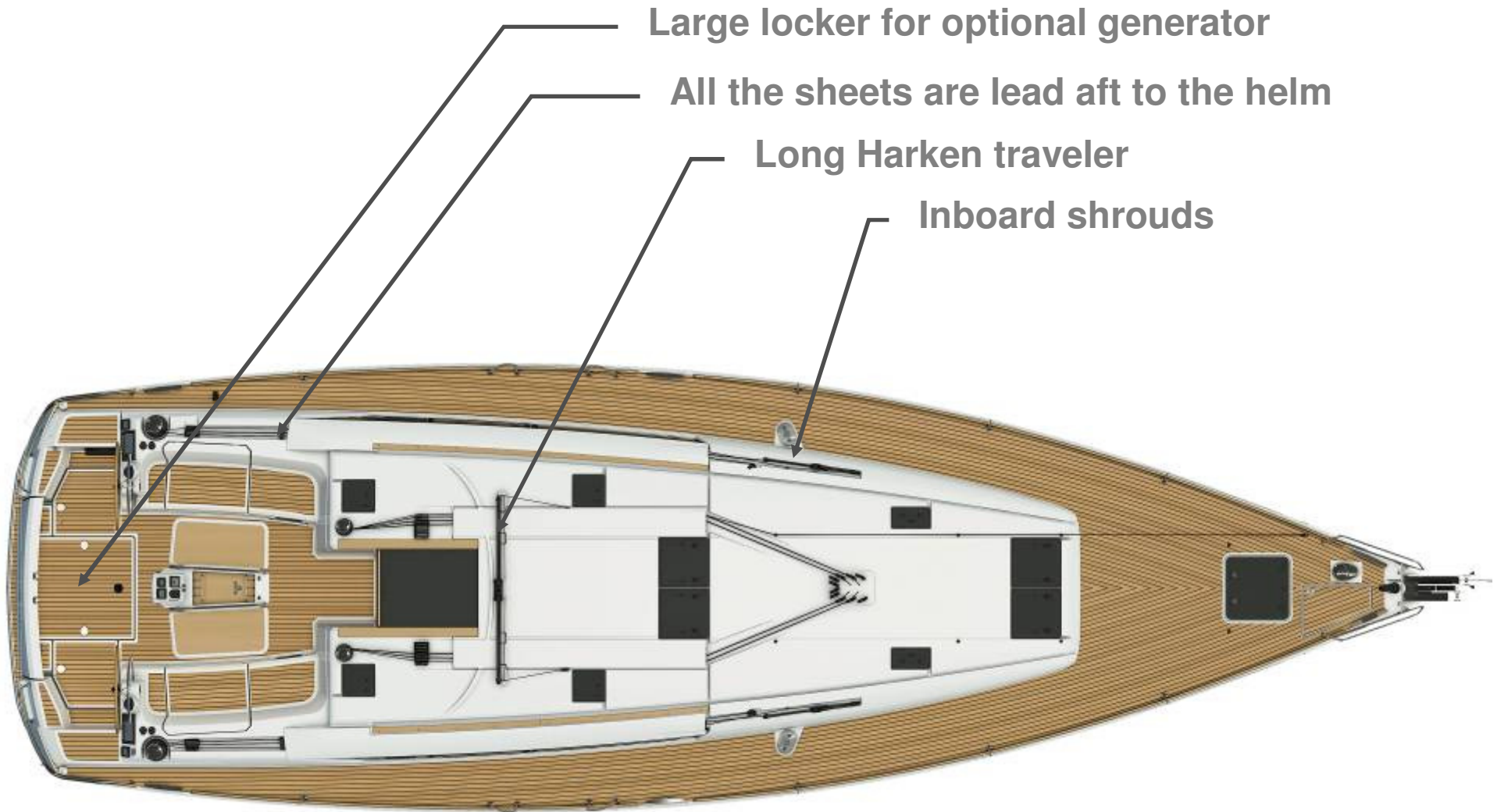



JEANNEAU

SUN ODYSSEY 509

Interior: Space, style and comfort

All the attributes of the Sun Odyssey range come together on this yacht:

- **Spacious interior** with choice of 4 layouts (from 3 to 5 cabins).
- **An exceptional layout in the saloon**, separate zones for living aboard plenty of functional details
- **Luxurious materials**, set off by all LED lighting
- **Numerous and practical storage lockers**, for offshore cruising with friends and family.
- **Light and ventilation**: 10 hull ports, long deckhouse windows, lots of opening ports and flush hatches.
- **Personalisation**: Choice of different fabrics, floorboards and a full list of options allow you to choose the combination that is right for you.





JEANNEAU

SUN ODYSSEY 509

LAYOUTS:

- 3 Cabin version, 2 heads:



- 4 Cabins version, 2 heads:



- 4 Cabins version, 4 heads:



- 5 Cabins version, 3 heads:





JEANNEAU

SUN ODYSSEY 509





JEANNEAU

SUN ODYSSEY 509





JEANNEAU

SUN ODYSSEY 509





JEANNEAU

SUN ODYSSEY 509

Forward owner's cabin:

Spacious head compartment with fully separate shower, overhanging berth, lots of storage and desk.



LED reading lights

Indirect lighting
(option)

Nightstands in
leatherette

2 large drawers
under the berth

Leatherette-lined
desk with mirror

Large hull ports



JEANNEAU

SUN ODYSSEY 509

Deluxe saloon table: (Option)

U-shaped saloon holds 8 people without interfering with the other zones aboard. View of the sea and easy access to the nav station

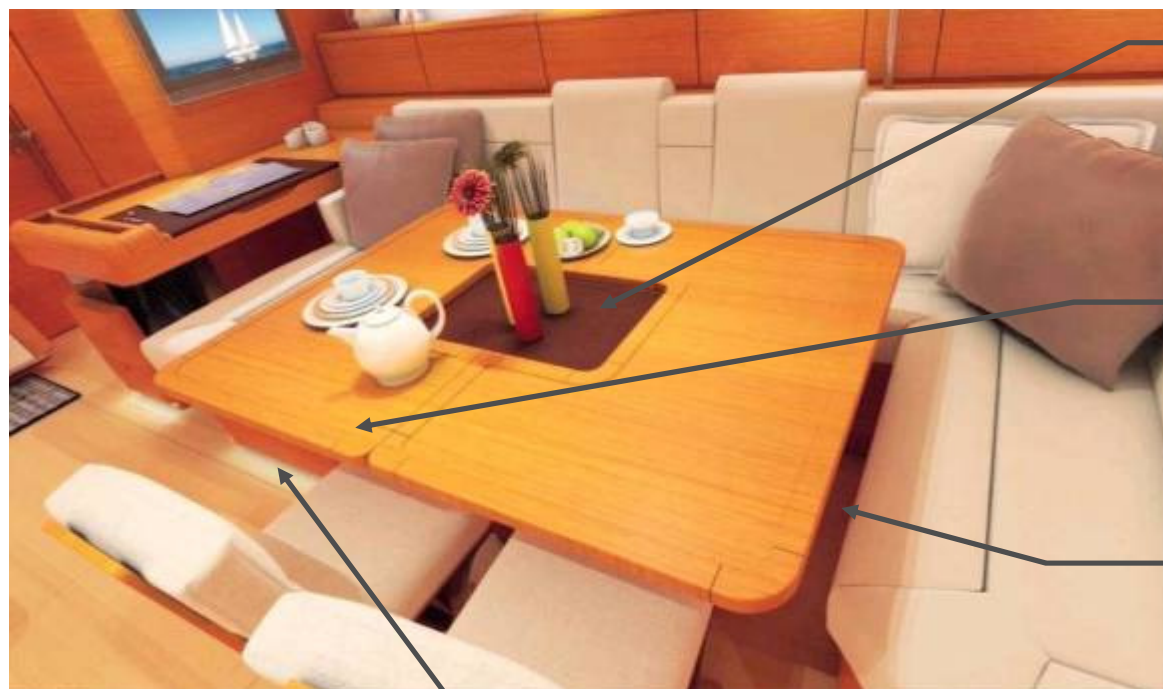

Deluxe table with central part lined with leatherette

Folding table top for easy access to seating

Fixed table base with storage

LED indirect lighting under kickboard (option)



JEANNEAU

SUN ODYSSEY 509

Lounge to starboard: (3 cabins version)

Relaxation zone with view of the sea and of the TV,
central bar cabinet, plush seating with armrests.



3 large hull ports

Several upholstery
choices, including the
possibility to have
differently coloured
backrest inserts*

Leatherette-lined bar
cabinet with pull out
drawer for bottles,
glasses and snacks

LED indirect lighting
under kickboard
(option)

* See details in the Marketing Book



JEANNEAU

SUN ODYSSEY 509

Galley: (3 cabins version)

New concept: T-shaped galley offers exceptional use of space. 2 people can work together without being in each others way.



Space for optional microwave

Easy access to upper cabinets with fiddles

175L Fridge with optional vertical door, 80L freezer

Large utensil drawer under the worktop

LED indirect lighting under kickboard (option)

Large storage compartment can house optional equipment (dishwasher, wine cooler, additional fridge compartment)



JEANNEAU

SUN ODYSSEY 509

Navigation Station:

Very large desk with lots of dedicated storage compartments, full integration of the latest entertainment and navigation technologies



Electrical panels placed behind a drop-down door

Option: integration of the GPS on TV screen with keyboard to control navigation functions

Leatherette-lined desk with space for a laptop computer

Book shelf with plexiglass dividers

LED indirect lighting under kickboard (option)



JEANNEAU

SUN ODYSSEY 509

Specifications :

Length overall	15.38 m	50 '5 "
Hull length	14.98 m	49 '1 "
Waterline length	13.92 m	45 '8 "
Beam	4.69 m	15 '4 "
Displacement	13900 kg	30644lbs
Deep keel draft	2.28 m	7 '5 "
Shoal keel draft	1.73 m	5 '8 "
Engine	75 Hp	55Kw
Cabins	3 to 5	
Berths	6 to 12	
Fuel capacity	240 l	63US gal
Water capacity	615 l	163US gal
Fridge capacity	255 l	67US gal
Standard sail area	114.0 m ²	1227Sq ft
Sail area: Performance Plus	134.0 m ²	1442Sq ft
Sail area: Performance Self-tacking	104.0 m ²	1119Sq ft
CE category	A12 - B14 - C16	Pers (*)
Architect	Philippe Briand / Jeanneau Design	

* Preliminary / Provisoire



JEANNEAU

For more information, contact Bay Yacht Agency 410-263-2311